

TECHNICAL MANUAL
OPERATOR'S, UNIT AND
DIRECT SUPPORT MAINTENANCE MANUAL
(INCLUDING REPAIR PARTS AND SPECIAL TOOLS LIST)
FOR

ELKAY 30 GALLON PER HOUR COOLER

This technical manual is an authentication of the manufacturer's commercial literature and does not conform with the format and the content requirements normally associated with Army technical manuals. This technical manual does, however, contain all essential information required to operate and maintain the equipment.

Approved for public release; distribution is unlimited.

HEADQUARTERS, DEPARTMENT OF THE ARMY
10 OCTOBER 1990

This technical manual is an authentication of the manufacturer's commercial literature and does not conform with the format and the content requirements normally associated with Army technical manuals. This technical manual does, however, contain all essential information required to operate and maintain the equipment.

Approved for public release; distribution is unlimited.

SUPPLEMENTARY INTRODUCTORY MATERIAL

1-1. Maintenance Forms and Records.

Department of the Army forms and procedures used for equipment maintenance will be those described by DA Pam 738-750, The Army Maintenance Management System.

1-2. Reporting Errors and Recommending Improvements.

You can help improve this manual. If you find any mistakes or if you know of a way to improve the procedures, please let us know. Mail your letters, DA Form 2028 (Recommended Changes to Publications and Blank Forms), or DA Form 2028-2 located in the back of this manual, directly to: Commander, U.S. Army Troop Support Command, ATTN: AMSTR-MCTS, 4300 Goodfellow Blvd., St. Louis, MO 63120-1798. A reply will be furnished to you.

1-3. Destruction of Army Material to Prevent Enemy Use.

Refer to TM 750-244-3 for instructions covering the destruction of Army Material to prevent enemy use.

1-4. Administrative Storage of Equipment.

a. Placement of equipment in administrative storage should be for short periods of time when a shortage of maintenance effort exists. Items should be in mission readiness within 24 hours or within the time factors as determined by the directing authority. During the storage period appropriate maintenance records will be kept.

b. Before placing equipment in administrative storage, current preventive maintenance checks and services should be completed. Shortcomings and deficiencies should be corrected, and all modification work orders (MWO's) should be applied.

c. Storage site selection. Inside storage is preferred for items selected for administrative storage. If inside storage is not available, trucks, vans, conex containers and other containers may be used.

i/(ii Blank)

**30 GPH COOLER
REMOTE MODEL**

INSTALLATION

1. This unit is intended for remote installation only. It is important to insure proper ventilation. Allow a minimum clearance of 6 inches in front and 6 inches in the rear of unit.
2. Water inlet and outlet are 3/8" FPT, located on left side of unit.
3. Connecting plumbing lines to be of copper or brass. Before connecting to cooler, thoroughly flush water lines to remove all foreign particles. If flushing does not remove all particles, install a water strainer in the supply line.
4. Connect cooler to the building supply line with a shut-off valve. Install a union connection between the shut-off valve and the cooler.
5. Electrical: Make sure power supply is identical in voltage, hertz, and phase to that specified on cooler serial plate. Never wire compressor directly to the power supply.

START-UP

1. Open supply line valve.
2. Purge, air from all water lines by operating bubbler valve of fountain to which cooler is connected. Steady stream flow assures all air removed.
3. Rotate fan to assure proper clearance and free fan action.
4. Connect to proper electrical power.

TROUBLE SHOOTING & MAINTENANCE

Temperature Control: Factory set for 50° F. water (+5±) under normal conditions. For colder water, adjust screw CW on item No. 2 (see diagram).

Ventilation: Cabinet Louvers and condenser fins should be periodically the above cleaned with brush, air hose or vacuum cleaner. Excess dirt or poor ventilation can cause no cold water and compressor cycling on the compressor overload protector.

Lubrication: Motors are lifetime lubricated.

ITEMIZED PARTS LIST

ITEM NO.	PART NO.	NAME OF PART
1	32176000	Cover-Insulation Box
2	48000072	Control-Cold
3	37268000	Heat Exchanger
4	33075000	Valve-By Pass
5	37269000	Cabinet
6	33484000	Conditioner
7	43543000	Blade-Fan
8	31713000	Motor-Fan
9	70196-C	Screw
10	19050000	Strainer
11	48000036	Compressor
12	30248C	Overload MRA 7950-118
13	48000069	Bale Strap
14	31663000	Grommet
15	19037000	Clip
16	30440C	Capacitor
17	61401-C	Evaporator Ass'y
18	40107001	Screw
19	31817000	Front Panel (Not Shown)
FOR 220/240V 50 Hz USE:		
8	38516000	Motor-Fan
11	37895000	Compressor
12	40405028	Overload
16	30441-C	Capacitor

NOTE: All correspondence pertaining to any of the above coolers or orders for repair parts **MUST** include model number and serial number of cooler name and part number of replacement part.

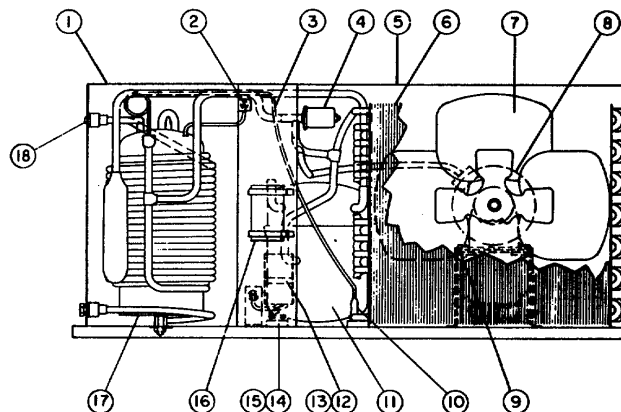
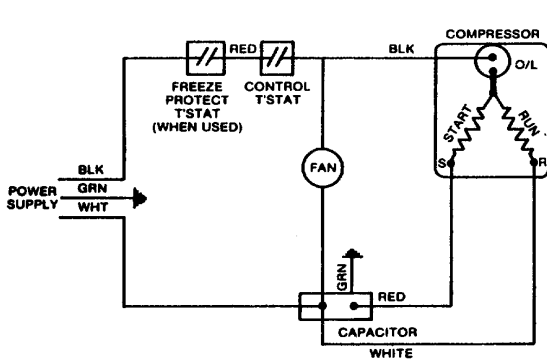

**ROUGHING IN DRAWING FOR:
30 GPH REMOTE COOLER**

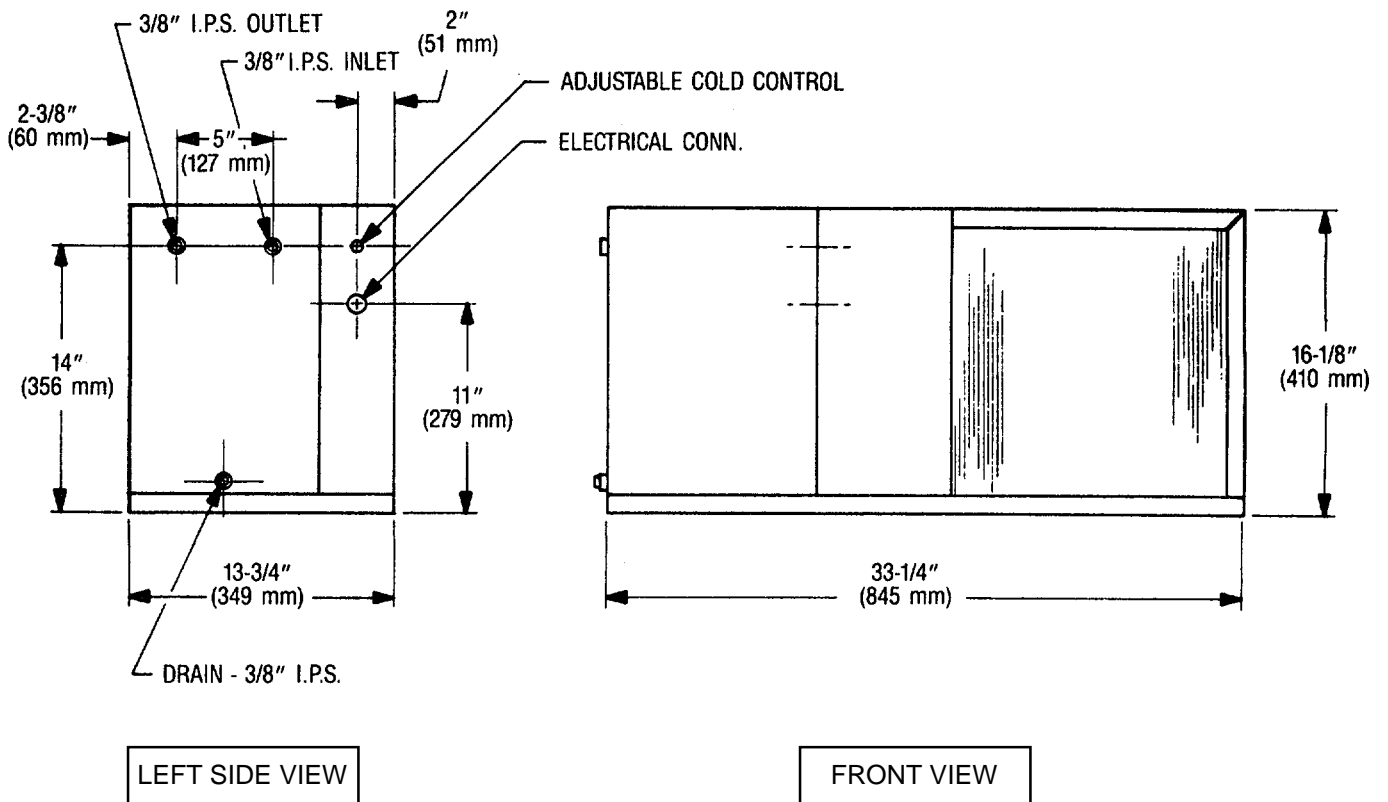

NOTE: This unit is intended for remote installation only. It is important to insure proper ventilation. Allow a minimum clearance of 18 inches in front and 18 inches in the rear of unit.

2222 CAMDEN COURT . OAK BROOK, ILLINOIS 60521

Cleaning and Servicing Instructions for Elkay Water Chiller

1. CLEANING

- a. Dry any water that has condensed on bottom of unit, under unit, or on components.
- b. Remove all dust and dirt from outside of components with vacuum cleaner. Remove all dust and debris from condenser fins.

2. SERVICING

- a. Check all plumbing and fittings for security and leaks. Check all electrical components for wear and security.
- b. Visually check supply and drain lines for proper routing and leakage. Check drain lines for obstructions.

1-1/(1-2 blank)

APPENDIX A

REFERENCES

A-1. Scope. This appendix contains all forms, pamphlets and technical manuals referenced in both the Air mobile and Semitrailer mounted Laboratories.

A-2. Forms.

Recommended Changes to Publications DA Form 2028
 DA Form 2028-2

Quality Deficiency Report..... SF 368
 Equipment Inspection and Maintenance Work Sheet DA Form 2404
 Hand Receipts..... DA Form 2062

A-3. Field Manuals.

Petroleum Testing Facilities:
 Laboratories and Kits..... FM 10-72
 Inspecting and Testing Petroleum Products..... FM 10-70
 ASTM Test Method Supplement to FM 10-92C1/C2

A-4. Technical Manuals.

Atlas-Copco Compressor TM 10-4310-392-13&P
 Alcor Jet Fuel Thermal Oxidation Tester Operating
 and Maintenance Manual..... TM 10-6635-210-13&P
 Bacharach Gas Alarm and Calibration Data TM 10-6665-297-13&P
 Brother Portable Typewriter..... TM 10-7430-218-13&P
 Chemtrix Field Ph Meter..... TM 10-6630-237-13&P
 Elkay Manufacturing 30 GPH Cooler..... TM 10-4130-240-13&P
 Emcee Micro-Separometer TM 10-6640-222-13&P
 Foxboro Pressure Recording Gauge..... TM 10-6685-365-13&P
 Gammon Aqua Glo Water Detector TM 10-6640-221-13&P
 Gammon Mini Monitor Fuel Sampling Kit..... TM 10-6630-230-13&P
 Jelrus Burn-Out Furnace TM 10-6640-231-13&P
 Koehler Cleveland Open Tester TM 10-6630-236-13&P
 Koehler Cloud and Pour Point Chamber TM 10-6630-238-13&P
 Koehler Copper Strip Corrosion Bomb Bath TM 10-6640-220-13&P
 Koehler Distillation Apparatus TM 10-6630-233-13&P
 Koehler Dropping Point Apparatus..... TM 10-6635-211-13&P
 Koehler Electric Pensky-Martins Tester TM 10-6630-231-13&P
 Koehler Foaming Characteristics Determination Apparatus TM 10-6640-228-13&P
 Koehler Kinematic Viscosity Bath..... TM 10-6630-239-13&P
 Koehler Tag Closed Cup Flash Tester..... TM 10-6630-235-13&P
 Lab-Line Explosion Proof Refrigerator TM 10-6640-219-13&P
 Lily Freezer..... TM 10-6640-234-13&P
 Millipore OM 39 Filter Holder..... TM 10-6640-225-13&P
 Millipore Vacuum Pump TM 10-6640-217-13&P
 Ohaus Harvard Trip Balance..... TM 10-6670-278-13&P
 Precision Gas-Oil Distillation Test Equipment..... TM 10-6630-219-13&P
 Precision General Purpose Water Bath TM 10-6640-229-13&P

Precision High Temperature Bronze Block Gum Bath	TM 10-6630-234-13&P
Precision General Purpose Ovens	TM 10-6640-218-13&P
Precision Heater Instruction Manual and Parts List	TM 10-6640-223-13&P
Precision Oxidation Stability Bath.....	TM 10-6640-232-13&P
Precision Pensky-Martens Flash Testers	TM 10-6630-231-13&P
Precision Reid Vapor Pressure Bath.....	TM 10-6640-226-13&P
Precision Slo-Speed Stirrer	TM 10-6640-224-13&P
Precision Universal Centrifuge	TM 10-6640-230-13&P
Precision Universal Penetrometer.....	TM 10-6640-228-13&P
Sargent-Welch Vacuum Pump	TM 10-4310-391-13&P
Sartorius Analytical Balance.....	TM 10-6670-277-13&P
Scotsman Cuber.....	TM 10-6640-227-13&P
Soltec VOM-Multimeter	TM 10-6625-217-13&P
Teel Self-Priming Centrifugal Pump	TM 10-6640-217-13&P
Teel Submersible Pump	TM 10-4320-320-13&P
Texas Instrument TI-503011 Calculator	TM 10-7420-210-13&P

A-5. Pamphlets.

The Army Maintenance Management System (TAMMS).....	DA Pam 738-750
---	----------------

A-6. Miscellaneous Publications.

The Army Integrated Publishing and Printing Program	AR 25-30
Laboratory, Airmobile, Aviation Fuel.....	MIL-L-52733A(ME)
Apparatus, Instruments, Chemicals, Furniture, and Supplies for Industrial, Clinical, College and Government Laboratories	Fisher Scientific Laboratories Catalog
Petroleum-Petrochemical Testing Equipment	Precision Scientific Catalog

APPENDIX B

MAINTENANCE ALLOCATION CHART

SECTION I. INTRODUCTION

B-1. General.

a. This section provides a general explanation of all maintenance and repair functions authorized at various maintenance categories.

b. The Maintenance Allocation Chart (MAC) in Section II designates overall authority and responsibility for the performance of maintenance functions on the identified end item or component. The application of the maintenance functions to the end item or component will be consistent with the capacities and capabilities of the designated maintenance categories.

c. Section III lists the tools and test equipment (both special tools and common tool sets) required for each maintenance function as referenced from Section II.

d. Section IV contains supplemental instructions and explanatory notes for a particular maintenance function.

B-2. Maintenance Functions. Maintenance functions will be limited to and defined as follows:

a. Inspect. To determine the serviceability of an item by comparing its physical, mechanical, and/or electrical characteristics with established standards through examination (e.g., by sight, sound, or feel).

b. Test. To verify serviceability by measuring the mechanical, pneumatic, hydraulic, or electrical characteristics of an item and comparing those characteristics with prescribed standards.

c. Service. Operations required periodically to keep an item in proper operating condition, i.e., to clean (includes decontaminate, when required), to preserve, to drain, to paint, or to replenish fuel, lubricants, chemical fluids, or gases.

d. Adjust. To maintain or regulate, within prescribed limits, by bringing into proper or exact position, or by setting the operating characteristics to specified parameters.

e. Align. To adjust specified variable elements of an item to bring about optimum or desired performance.

f. Calibrate. To determine and cause corrections to be made or to be adjusted on instruments or test, measuring, and diagnostic equipments used in precision measurement. Consists of comparisons of two instruments, one of which is a certified standard of knob accuracy, to detect and adjust any discrepancy in the accuracy of the instrument being compared.

g. Remove/Install. To remove and install the same item when required to perform service or other maintenance functions. Install may be the act of emplacing, seating, or fixing into position a spare, repair part, or module (component or assembly) in a manner to allow the proper functioning of an equipment or system.

h. Replace. To remove an unserviceable item and install a serviceable counterpart in its place. "Replace" is authorized by the MAC and is shown as the third position code of the SMR code.

i. Repair. The application of maintenance services,¹ including fault location/troubleshooting² removal/installation, and disassembly/assembly procedures³ and maintenance actions⁴ to identify troubles and restore serviceability to an item by correcting specific damage, fault, malfunction, or failure in a part, subassembly, module (component or assembly), end item, or system.

j. Overhaul. That maintenance effort (service/action) prescribed to restore an item to a completely serviceable/operational condition as required by maintenance standards in appropriate technical publications (i.e, DMWR). Overhaul is normally the highest degree of maintenance performed by the Army. Overhaul does not normally return an item to like-new condition.

k. Rebuild. Consists of those services/actions necessary for the restoration of unserviceable equipment to a like-new condition in accordance with original manufacturing standards. Rebuild is the highest degree of materiel maintenance applied to Army equipment. The rebuild operation includes the act of returning to zero those age measurements (hours/miles, etc.) considered in classifying Army equipment/components.

B-3. Explanation Of Columns In The MAC, Section II.

a. Column 1. Group Number. Column 1 lists functional group code numbers, the purpose of which is to identify maintenance significant components, assemblies, subassemblies, and modules with the next higher assembly. End item group number shall be "00."

b. Column 2. Component/Assembly. Column 2 contains the names of components, assemblies, subassemblies, and modules for which maintenance is authorized.

c. Column 3. Maintenance Function. Column 3 lists the functions to be performed on the item listed in column 2. (For a detailed explanation of these functions, see paragraph B-2.)

d. Column 4. Maintenance Category. Column 4 specifies, by the listing of a work time figure in the appropriate subcolumn(s), the category of maintenance authorized to perform the function listed in column 3. This figure represents the active time required to perform that maintenance function at the indicated category of maintenance. If the number or complexity of the tasks within the listed maintenance function vary at different maintenance categories, appropriate work time figures will be shown for each category. The work time figure represents the average time required to restore an item (assembly, subassembly, component, module, end item, or system) to a serviceable condition under typical field operating conditions. This time includes preparation time (including any necessary disassembly/ assembly time), troubleshooting/fault location time, and quality assurance/quality control time in addition to the time required to perform the specific tasks identified for the maintenance functions authorized in the maintenance allocation chart. The symbol designations for the various maintenance categories are as follows:

-
- 1 *Services - inspect, test, service, adjust, align, calibrate, and/or replace.*
 - 2 *Fault locate/troubleshoot-the process of investigating and detecting the cause of equipment malfunctioning; the act of isolating a fault within a system or unit under test (UUT).*
 - 3 *Disassemble/assemble - encompasses the step-by-step taking apart (or breakdown) of a spare/functional group coded item to the level of its least componency identified as maintenance significant (i.e., assigned an SMR code) for the category of maintenance under consideration.*
 - 4 *Actions - welding, grinding, riveting, straightening, facing, remachining, and/or resurfacing.*

- C.....Operator/Crew
- O.....Unit Maintenance
- F.....Direct Support Maintenance
- H.....General Support Maintenance
- D.....Depot Maintenance

e. Column 5. Tools and Equipment. Column 5 specifies, by code, those common tool sets (not individual tools) and special tools, TMDE, and support equipment required to perform the designated function.

f. Column 6. Remarks. This column shall, when applicable, contain a letter code, in alphabetic order, which shall be keyed to the remarks contained in section IV.

B-4. Explanation Of Columns In Tool And Test Equipment Requirements, Section III.

a. Column 1. Reference Code. The tool and test equipment reference code correlates with a code used in the MAC, section II, column 5.

b. Column 2. Maintenance Category. The lowest category of maintenance authorized to use the tool or test equipment.

c. Column 3. Nomenclature. Name or identification of the tool or test equipment.

d. Column 4. National Stock Number. The National stock number of the tool or test equipment.

e. Column 5. Tool Number. The manufacturer's part number.

B-5. Explanation Of Columns In Remarks, Section IV.

a. Column 1. Reference Code. The code recorded in column 6, Section II.

b. Column 2. Remarks. This column lists information pertinent to the maintenance function being performed as indicated in the MAC, section II.

SECTION II. MAINTENANCE ALLOCATION CHART

(1) GROUP NUMBER	(2) COMPONENT ASSEMBLY	(3) MAINTENANCE FUNCTION	(4) MAINTENANCE CATEGORY					(5) TOOLS AND EQUIPMENT	(6) REMARKS
			C	O	F	H	D		
01	COOLER WATER 30 GPH	INSPCET REPLACE REPAIR	0.1	1.0	2.0			1,2,3	

**SECTION III. TOOL AND TEST EQUIPMENT REQUIREMENTS
FOR
MAINTENANCE ALLOCATION CHART**

(1) TOOL OR TEST EQUIPMENT REF CODE	(2) MAINTENANCE CATEGORY	(3) NOMENCLATURE	(4) NSN	(5) TOOL NUMBER
1	F	MULTIMETER, 0-500V	6625-00-691-2453	
1	F	SOLDERING GUN, 115V, 60 CYCLE COMPLETE WITH SOLDER & CASE	343900-618-6623	
3	F	SHOP EQUIPMENT, AUTOMOTIVE MAINTENANCE AND REPAIR: COMMON #1 (LESS POWER)	4910-00-754-0654	SC 4910-95- CL-A74

SECTION IV. REMARKS

NOT APPLICABLE

**APPENDIX C
COMPONENTS OF END ITEM AND BASIC ISSUE ITEMS LISTS**

NOT APPLICABLE

C-1/(C-2 Blank)

APPENDIX D

ADDITIONAL AUTHORIZATION LIST

NOT APPLICABLE

D-1(D-2 Blank)

**APPENDIX E
EXPENDABLE/DURABLE SUPPLIES AND MATERIALS LIST**

NOT APPLICABLE

E-1/(E-2 Blank)

By Order of the Secretary of the Army:

CARL E. VUONO
General, United States Army
Chief of Staff

Official:

THOMAS F. SIKORA
Brigadier General, United States Army
The Adjutant General

DISTRIBUTION:

To be distributed in accordance with DA Form 12-25E, Operator, Unit and Direct Support Maintenance requirements for Laboratory, Petroleum, MTD

This page only for NON-SOFTWARE-related TM errors/improvements.

RECOMMENDED CHANGES TO EQUIPMENT TECHNICAL PUBLICATIONS



SOMETHING WRONG WITH THIS PUBLICATION?

THEN...JOT DOWN THE DOPE ABOUT IT ON THIS FORM. CAREFULLY TEAR IT OUT. FOLD IT AND DROP IT IN THE MAIL.

FROM: (PRINT YOUR UNIT'S COMPLETE ADDRESS)

DATE SENT

PUBLICATION NUMBER	PUBLICATION DATE	PUBLICATION TITLE
--------------------	------------------	-------------------

BE EXACT PIN-POINT WHERE IT IS				IN THIS SPACE TELL WHAT IS WRONG AND WHAT SHOULD BE DONE ABOUT IT:
PAGE NO.	PARA-GRAPH	FIGURE NO.	TABLE NO.	

TEAR ALONG PERFORATED LINE.

PRINTED NAME GRADE OR TITLE AND TELEPHONE NUMBER	SIGN HERE
--	-----------

The Metric System and Equivalents

Linear Measure

1 centimeter = 10 millimeters = .39 inch
 1 decimeter = 10 centimeters = 3.94 inches
 1 meter = 10 decimeters = 39.37 inches
 1 dekameter = 10 meters = 32.8 feet
 1 hectometer = 10 dekameters = 328.08 feet
 1 kilometer = 10 hectometers = 3,280.8 feet

Weights

1 centigram = 10 milligrams = .15 grain
 1 decigram = 10 centigrams = 1.54 grains
 1 gram = 10 decigram = .035 ounce
 1 dekagram = 10 grams = .35 ounce
 1 hectogram = 10 dekagrams = 3.52 ounces
 1 kilogram = 10 hectograms = 2.2 pounds
 1 quintal = 100 kilograms = 220.46 pounds
 1 metric ton = 10 quintals = 1.1 short tons

Liquid Measure

1 centiliter = 10 milliliters = .34 fl. ounce
 1 deciliter = 10 centiliters = 3.38 fl. ounces
 1 liter = 10 deciliters = 33.81 fl. ounces
 1 dekaliter = 10 liters = 2.64 gallons
 1 hectoliter = 10 dekaliters = 26.42 gallons
 1 kiloliter = 10 hectoliters = 264.18 gallons

Square Measure

1 sq. centimeter = 100 sq. millimeters = .155 sq. inch
 1 sq. decimeter = 100 sq. centimeters = 15.5 sq. inches
 1 sq. meter (centare) = 100 sq. decimeters = 10.76 sq. feet
 1 sq. dekameter (are) = 100 sq. meters = 1,076.4 sq. feet
 1 sq. hectometer (hectare) = 100 sq. dekameters = 2.47 acres
 1 sq. kilometer = 100 sq. hectometers = .386 sq. mile

Cubic Measure

1 cu. centimeter = 1000 cu. millimeters = .06 cu. inch
 1 cu. decimeter = 1000 cu. centimeters = 61.02 cu. inches
 1 cu. meter = 1000 cu. decimeters = 35.31 cu. feet

Approximate Conversion Factors

To change	To	Multiply by	To change	To	Multiply by
inches	centimeters	2.540	ounce-inches	newton-meters	.007062
feet	meters	.305	centimeters	inches	.394
yards	meters	.914	meters	feet	3.280
miles	kilometers	1.609	meters	yards	1.094
square inches	square centimeters	6.451	kilometers	miles	.621
square feet	square meters	.093	square centimeters	square inches	.155
square yards	square meters	.836	square meters	square feet	10.764
square miles	square kilometers	2.590	square meters	square yards	1.196
acres	square hectometers	.405	square kilometers	square miles	.386
cubic feet	cubic meters	.028	square hectometers	acres	2.471
cubic yards	cubic meters	.765	cubic meters	cubic feet	35.315
fluid ounces	milliliters	29.573	cubic meters	cubic yards	1.308
pints	liters	.473	milliliters	fluid ounces	.034
quarts	liters	.946	liters	pints	2.113
gallons	liters	3.785	liters	quarts	1.057
ounces	grams	28.349	liters	gallons	.264
pounds	kilograms	.454	grams	ounces	.035
short tons	metric tons	.907	kilograms	pounds	2.205
pound-feet	newton-meters	1.356	metric tons	short tons	1.102
pound-inches	newton-meters	.11296			

Temperature (Exact)

°F	Fahrenheit temperature	5/9 (after subtracting 32)	Celsius temperature	°C
----	------------------------	----------------------------	---------------------	----

PIN: 046575-000